

VALVE PRESSURE REDUCING

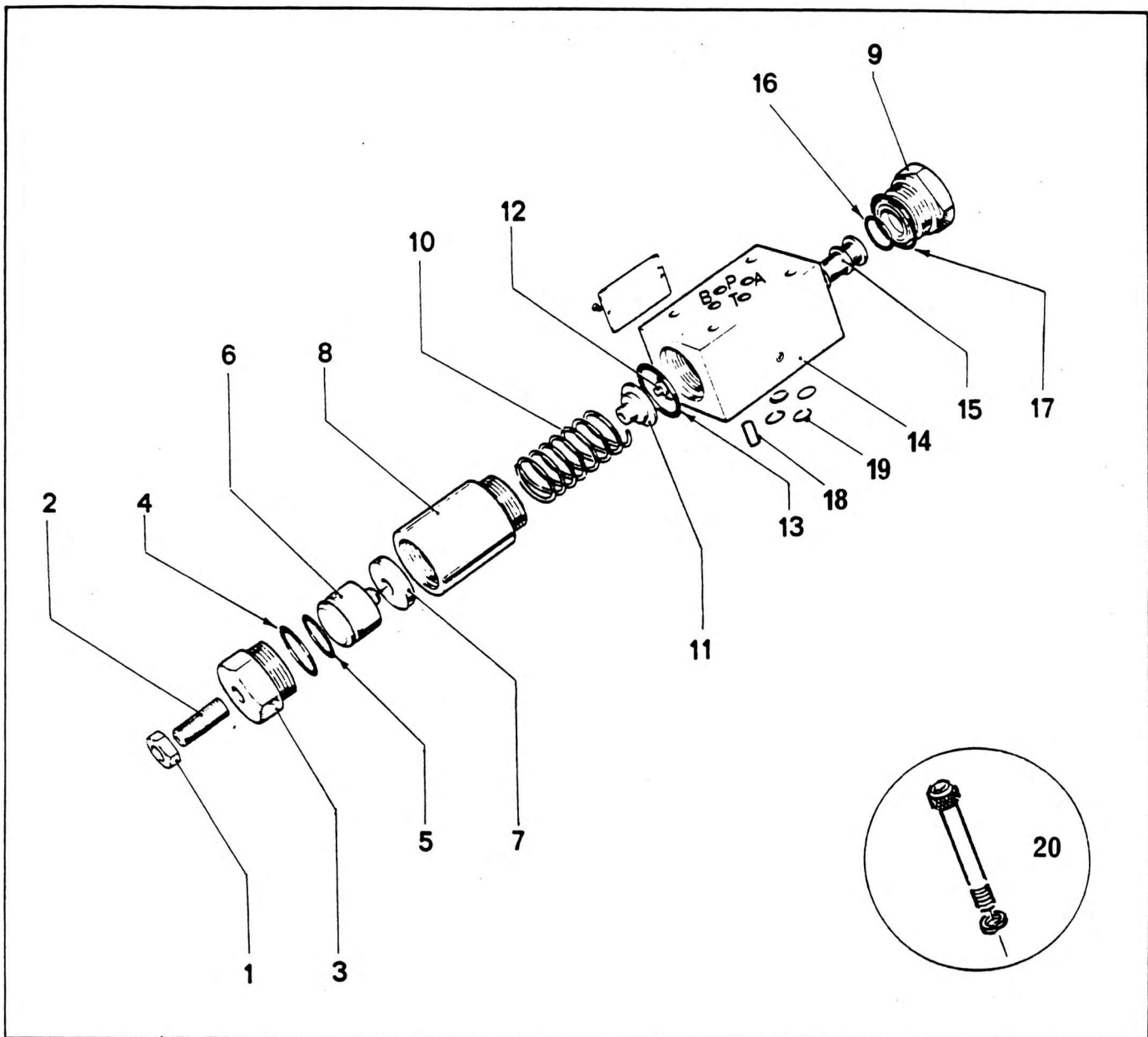

NO.	PART NO.	QTY.	DESCRIPTION	NO.	PART NO.	QTY.	DESCRIPTION
-	7-926-990424	1	Valve Complete	15	-	1	Spool
*	8391697	1	Gasket Kit	16*	-	1	'O' Ring
1	-	1	Locknut	17*	-	1	'O' Ring
2	-	1	Setscrew	18	-	1	Dowel
3	-	1	Plug	19*	-	1	'O' Ring
4 *	-	1	'O' Ring	20	8391699	1	Bolt Kit
5 *	-	1	'O' Ring	ORDERING ITEMS			
6	-	1	Adjuster Piston	Individual items illustrated are intended to aid dismantling and re-assembly of this unit. Items without part numbers are not available as spares.			
7	-	1	Carrier	Valve pre-set at 17 bar			
8	-	1	Spring Housing	7-926-990424			
9	-	1	Plug	Issue No. 00			
10	-	1	Spring				
11	-	1	Spring Seat				
12	-	1	Rivet				
13*	-	1	'O' Ring				
14	-	1	Valve Body				